



SFB Series 1 Pressure Blower Package



A quality rotary lobe blower package direct from the manufacturer

The SFB Series 1 blower package has been engineered, optimized and packaged by the blower manufacturer! Every component is the result of a careful selection to ensure optimum performance and each of these components is backed by Ingersoll Rand warranty and service! This is the only full line factory engineered blower package on the market with enclosure that features two lobe and three lobe blowers.

Compact – Efficient – Affordable – Fast delivery

ISO 9001



SFB Series 1

Pressure Blower Package

Standardized packages

Model	Disc. Connection (MNPT)	Max Motor size (HP)	Max Flow (ICFM)	Max. Pressure* (PSIG)	Height (inches)	Length (inches)	Width (inches)	Weight (lbs.)	Lobe type
222	2	5	80	11	34	34	34	525	⊗
223	2	5	150	6	34	34	34	525	⊗
231	2	15	165	14	36	34	34	1000	⊗
232	2	15	200	11	36	34	34	1000	⊗
241	3	20	200	15	38	35	35	1100	⊗
251	3	25	280	15	39	35	35	1350	⊗
233	3	15	360	6	42	40	43	1100	⊗
242	3	20	350	9	44	40	43	1175	⊗
801	3	15	140	14	42	40	43	1050	⊕
802	3	30	220	15	42	40	43	1225	⊕
243	4	20	550	6	40	41	43	1200	⊗
252	4	20	550	8	42	41	43	1275	⊗
253	4	20	650	6	42	41	43	1325	⊗
803	4	30	490	15	44	46	42	1750	⊕
804	4	40	550	15	44	47	42	2100	⊕

Dimensions are for estimating purposes only. *Pressure and Speed will be as Calculated from Hibon PD Selection Program.

⊗ Two lobe impeller ⊕ Three lobe impeller

Standard features

- Available with or without acoustical enclosure
- Fixed tension cog belt type – no retightening required
- Compact design
- Proven two or three lobe blower technology

All units come with:

- Hibon Blower
- Inlet filter
- Inlet filter differential pressure gauge
- Discharge pressure gauge
- Base with integral discharge silencer
- Weighted type pressure relief valve
- Anti-vibration mounting pads
- High efficiency TEFC motor (50/60Hz)
- OSHA certified belt guard
- Motor slide base for easy belt replacement
- Discharge flex coupling and clamps
- Discharge check valve

Optional acoustical enclosure features

- Noise reduction to 85 dBA +/- 3 dB with enclosure depending on model and operating conditions
- Electrical fan to maintain optimal blower operating temperature with ODP (110/120 volt)
- Enclosure mounted differential pressure and discharge pressure gauges
- Removable doors for ease of maintenance
- Rust proof polyester paint suitable for indoor/outdoor installation
- Standard size for all blower packages:
44"W x 36"L x 60"H (250 lbs.)
Except for 803 and 804 models which is:
52"W x 52"L x 78"H (550 lbs.)

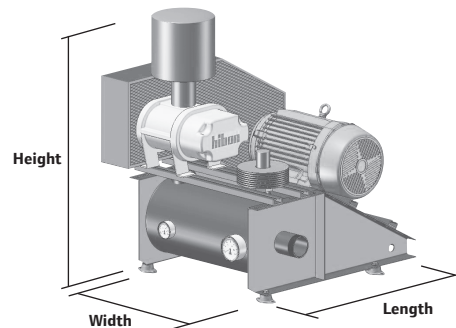

Hibon Inc.
 (An Ingersoll Rand Company)
 12055, Cote de Liesse
 Dorval, QC H9P 1B4
 Canada

Tel: 514 631-3501
 Fax: 514 631-3502
 1-888-704-4266
 www.hibon.com

IR Ingersoll Rand
 Industrial Technologies